

# SPC-618WE

## 18.5" FHD TFT LED LCD Touch Panel Computer with Intel® Raptor Lake-U Platform with IECEx/ATEX and Class I Division II Explosion-Proof certification



### Introduction

Advantech's SPC-618WE Explosion-Protected Touch panel computer, is powered by Intel Raptor Lake-U Intel Core processors. With its fan-less design, SPC-618WE delivers high performance that not simply meets customer demands for a daily-operation control panel, but a genuine Industry 4.0-era-tailored Industrial PC that features bountiful I/Os including two USB 3.2 ports, one USB Type-C port, expansions with sTLC Solid State Drive and WiFi module that support for ultra speed data transmission. The system was both IP66 and IEC Ex/IECEX/ATEX and Class I Division Explosion-Protected certified, therefore is suitable for hazardous environment.

### Specifications

#### General

- **BIOS** AMI UEFI
- **Certification** BSMI, CCC, CE, FCC Class A, IECEx/ATEX Zone 2/22 explosion proof certification Class I Division II explosion proof certification
- **Cooling System** Fanless design
- **Dimensions (W x H x D)** 479.3 x 300.3 x 80 mm
- **Enclosure** Front bezel: Die cast aluminum alloy Back housing: Die cast aluminum alloy
- **Mounting** Panel Mount
- **OS Support** Windows 11 LTSC
- **Security** TPM 2.0 (built-in)
- **Power Consumption** Typ. 46W; Max. 82W
- **Power Input** 19 - 24 V<sub>DC</sub> ± 15%
- **Watchdog Timer** 15-255 sec (system)
- **Weight (Net)** 6KG

#### System Hardware

- **CPU** 13th Gen. Intel® Core™ i7-1365URE 1.7 GHz Deca-core processor
- **Memory** Single DDR5 4800 SO-DIMM RAM 32GB
- **LAN** 2 x 2.5 GbE with Intel® i226
- **Storage** 1x M.2 2280 sTLC Solid State Drive 256 GB (Baseline) sTLC Solid State Drive 512 GB (Option for custom model\*) 1 x 2.5 SATA sTLC Solid State Drive 256 GB (Option for custom model\*) sTLC Solid State Drive 512 GB (Option for custom model\*)

\*Detailed information listed in "Expansion Component for Custom Model"

- **I/O** 1 x Displayport 1.4a (Video output) 1 x USB Type-C (USB 3.2 Gen.2, DP 1.4a, 5V w/ 3A max) 2 x USB 3.2 (Gen.1) 2 x USB 2.0 2 x RS-232/422/485 (Optional) 2 x 4Ω Speaker for Audio out

### Features

- Industrial-grade 18.5" FHD TFT LCD with 50K lifetime and LED backlight
- 13th Gen. Intel® Core™ i7-1365URE deca-core processor
- Built in single DDR5 4800 RAM with 32GB capacity
- Built in sTLC SSD of 256GB with extreme longevity and reliability
- Compact, fanless embedded system with aluminum alloy front bezel and chassis grounding protection
- Specialized enhanced impact proof touchscreen with PCAP touch control and IP66-rated front panel
- Support TPM2.0 hardware security
- IECEx/ATEX explosion proof certification for Zone 2/22
- Class I Division II explosion proof certification

#### LCD Display

- **Display Type** FHD TFT LED LCD
- **Display Size** 18.5"
- **Max. Resolution** 1920 x 1080
- **Max Colour** 16.7M
- **Luminance cd/m<sup>2</sup>** 350 cd/m<sup>2</sup>
- **Viewing Angle (H/V°)** 178°/178°
- **Backlight Life** 50,000 hrs
- **Contrast Ratio** 1000:1

#### Touchscreen

- **Light Transmission** Above 85%
- **Resolution** Linearity
- **Type** PCAP touch screen

#### Environment

- **Humidity** 95% RH @ 40°C, non-condensing
- **Ingress Protection** IP65-rated front panel
- **Operating Temperature** -20~60 °C (-4~140 °F) (w/o air flow)
- **Storage Temperature** -30~70 °C (-22~158 °F)
- **Vibration Protection** With SSD: 1 Grms (5 ~ 500 Hz) (Operating, random vibration)

### Rear View

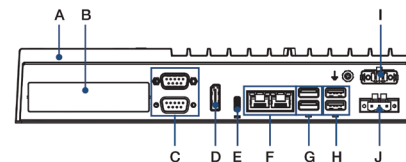

- A. Chassis
- B. iDoor Slot (Not Expandable)
- C. RS-232/422/485
- D. Display Port
- E. USB Type-C
- F. 2.5GbE LAN
- G. USB 3.2
- H. USB 2.0
- I. Remote Button
- J. Power DC IN

## Dimensions

Unit: mm

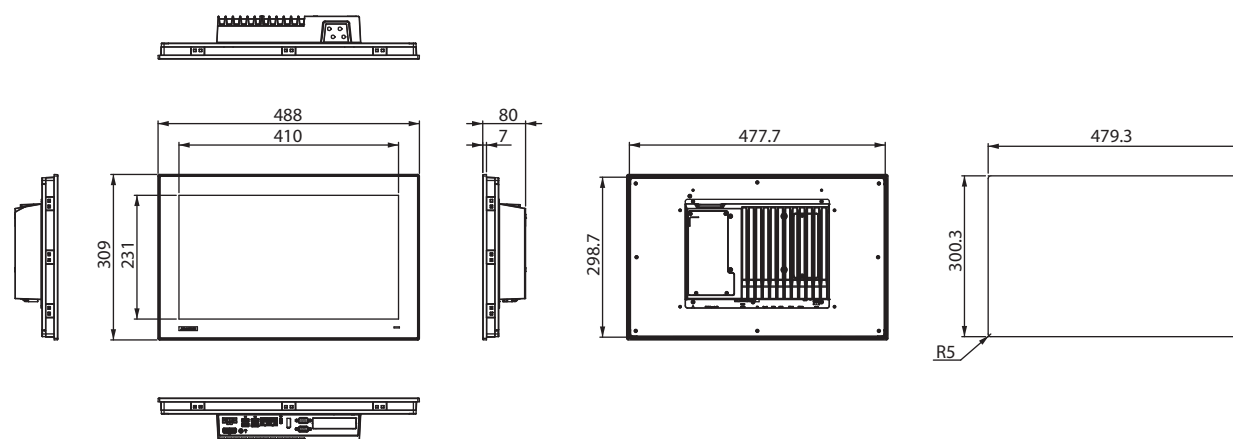

**Panel Cut-out Dimensions: 479.3 x 300.3mm (18.87 x 11.82 in)**

## Ordering Information

- **SPC-618WE-PUD75A** 18.5" FHD Panel PC, ATEX Explosion-Protected certification, 13th Gen. Intel® i7-1365URE 1.7 GHz Deca-core processor

## Optional Accessories

- **96PSA-A150W24T2-4** 150W 24V<sub>DC</sub> power supply
- **1702002600** Power cable (US) 1.8 M
- **1702002605** Power cable (EU) 1.8 M
- **1702031801** Power cable (UK) 1.8 M
- **1700000596-11** Power cable (China/Australia) 1.8 M

## Embedded OS

- **20701WLH1S0004** Win11 LTSC for SPC-618WE

## Explosion Proof Certification



## Expansion Component for Custom Model

Explosion Proof Certified Expansion Components		Description
M.2 2280 SSD (Baseline)	SQF-S8BZ4-256GDSDE	SQF M.2 2280 SSD 256GB 3D sTLC
Option1	SQF-S8BZ4-512GDSDE	SQF M.2 2280 SSD 512GB 3D sTLC
2.5" SATA SSD (Baseline)	None	None
Option1	SQF-S25Z4-256GDSDE	SQF 2.5" SATA SSD 256GB 3D sTLC
Option2	SQF-S25Z4-512GDSDE	SQF 2.5" SATA SSD 512GB 3D sTLC

## Packing List

Item	Part No.	Description	Qty
Grounding cable	1703011001-11	A Cable G-TEM 4.3 100CM C=GR/Y	1
Power Connector	1652007930-01	Plug-In Block 1x3P/5.08mm/PA66/F/VA	1
Warranty	2190000902	CARDBOARD-WARRANTY REV. A2	1
VESA Screw	1930005204	Screw M4x10L R/S DH=6.8x2.50 + ST ZBK PL	4
China RoHS	202KAKMCO0	China rohs for AKMC model name 1st ed	1

Please contact Advantech for certificate compliance.